

# SUS-15~50

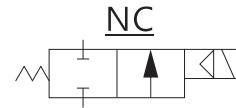
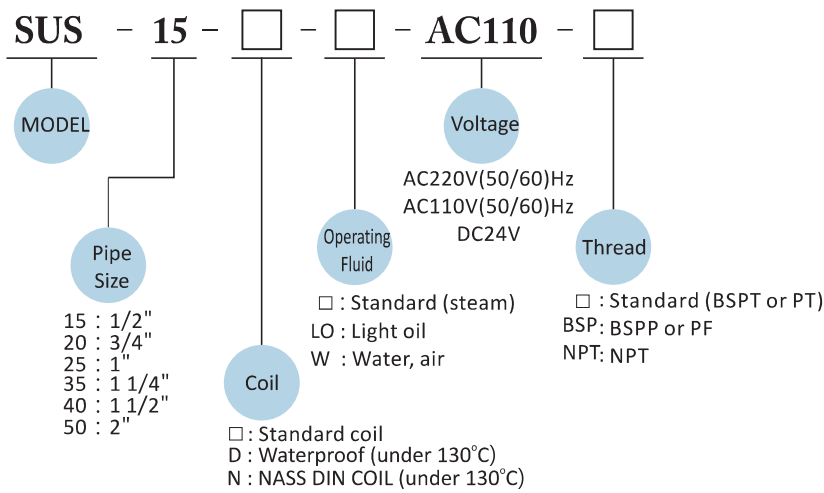

UD Series

## PRODUCT DESCRIPTION

- SUS series is multiplex, piston guiding, conductive and normally closed (NC) 2/2 way solenoid valve.
- Applied fluid type : water, air, steam, light oil
- Recommend to apply to frequent operation

## CAUTIONS:

- Before pipelining, the pipe line must be very clean without any contaminants or impurity.
- To extend the lifetime, Y-line filter should be installed in the front end of solenoid valve.
- AC voltage tolerance: ± 10%; DC voltage tolerance: ± 1%
- It should be installed horizontally; vertical installation is not advisable.

## Not Suitable For Fluid As Below:

- Liquid status when it is in high temperature; solid status when it is in low temperature.
- Corrosive fluid
- Viscosity over 20cst

## MATERIAL:

PARTS	Coil	Tube	Spring	Core	Plug	Piston Spring	Piston	Piston plug	Valve body
MATERIAL	Special copper wire (H class)	Stainless steel	Stainless steel	Stainless steel	PTFE	Stainless steel	Stainless steel	PTFE	Stainless steel

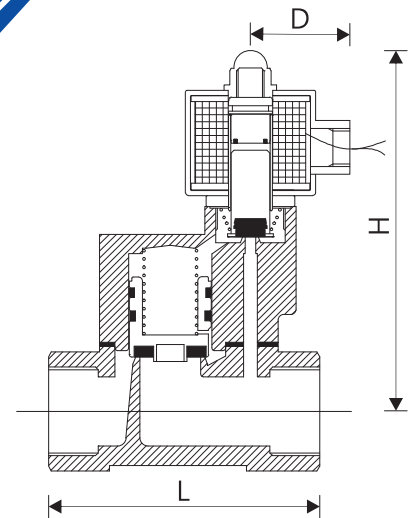

## SPECIFICATION

MODEL	Waterproof DIN/flying lead Coil	NASS DIN Coil (IP65)	PIPE SIZE	CV	ORIFICE	FLUID TEMP. (°C)	Operating Pressure kgf / cm <sup>2</sup> (bar)					Dimension (mm)			Weight (kg)
							Water	Air	Steam	Light oil	Gas	L	H	D	
SUS-15	●	●	1/2"	4.0	17mm	-5°C ~ +185°C	0.5~10	0.5~10	0.5~10	0.5~10		84	115	48	1.38
SUS-20	●	●	3/4"	6.0	17mm	-5°C ~ +185°C	0.5~10	0.5~10	0.5~10	0.5~10		84	120	48	1.43
SUS-25	●	●	1"	12	22mm	-5°C ~ +185°C	0.5~10	0.5~10	0.5~10	0.5~10		98	132	48	1.88
SUS-35	●	●	1 1/4"	18	30mm	-5°C ~ +185°C	1~10	1~10	1~10	1~10		123	142	48	2.62
SUS-40	●	●	1 1/2"	22	30mm	-5°C ~ +185°C	1~10	1~10	1~10	1~10		123	146	48	2.72
SUS-50	●	●	2"	48	50mm	-5°C ~ +185°C	1~10	1~10	1~10	1~10		167	173	48	5.45